



Equipment for the Foodservice Industry

value + quality + service

X-LINE Mega Top Prep Tables

CMDR3-72VCX



CMDR3-72VCX Features

Features:

- Stainless steel interior and exterior
- Round corner design for inner bottom board
- Polyethylene cutting board
- Self-closing swing door w/90°stay open feature
- Recessed handles
- Removable gasket that is easy to clean and replace
- Adjustable/removable plastic coated wire shelves
- Enclosed condiment section
- R290 refrigeration system holds 33°F to 41°F (0.5°C to 5°C)
- Insulated lid on prep units helps to maintain food freshness
- Casters for easy movement
- Adjustable temperature set point and defrost frequency
- Error codes to diagnose service issues
- Condenser access at rear of unit, slides out for easy maintenance

Warranty:

- 2 year parts and labour; 5 years on compressor
- Specifications subject to change without notice.



CMDR3-72VCX Specifications

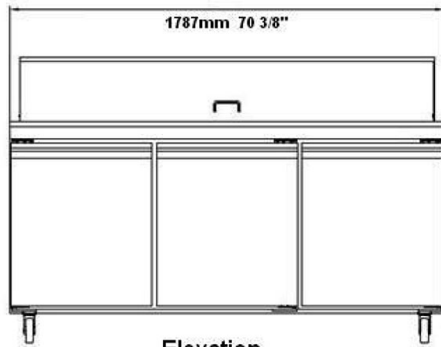

Elevation

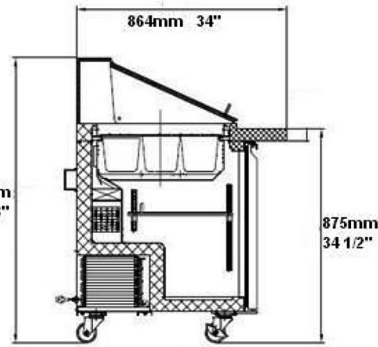

Section View

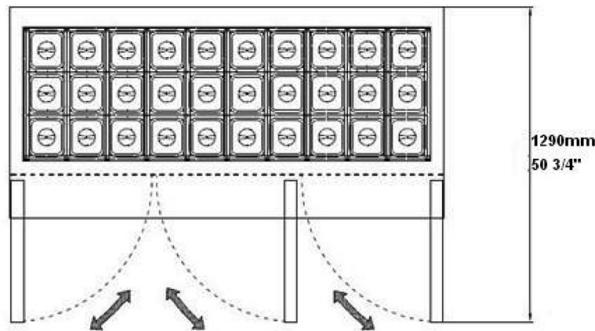

Plan

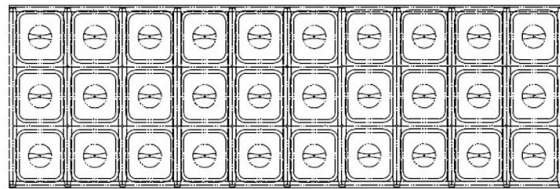

PAN LAYOUTS
30 (pcs) 1/6 pans

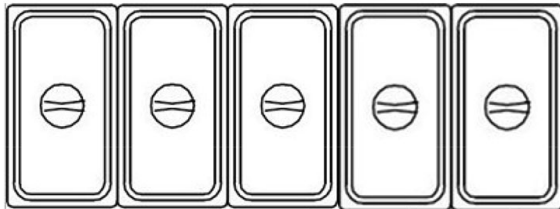

PAN LAYOUTS
5 (pcs) 1/1 pans

Model	Doors	Shelves	Dimension (mm) (inch)			HP	Voltage	Amps	Capacity (L) (Cu Ft.)	Net Weight (KG) (LBS)	NEMA Config.
			L	D	H						
CMDR3-72VCX	3	3	1787	864	1166	1/2	115/60/1	6.48	440	172	5-15P 
			70.4	34	45.9				15.5	380	