



Equipment for the Foodservice Industry  
value + quality + service

## X-LINE 27" Refrigerated Salad/ Sandwich Prep Table

Model No:  
**CSDR1-27VCX**



### CSDR1-27VCX

### Features

#### Features:

- Stainless steel interior and exterior
- Round corner design for inner bottom board
- Polyethylene cutting board
- Self-closing swing right hinged door w/90°stay open feature
- Recessed handles
- Removable gasket that is easy to clean and replace
- Adjustable/removable plastic coated wire shelves
- Enclosed condiment section
- R290 refrigeration system holds 33°F to 41°F (0.5°C to 5°C)
- Insulated lid on prep units helps to maintain

#### food freshness

- Casters for easy movement
- Adjustable temperature set point and defrost frequency
- Error codes to diagnose service issues
- Condenser access at rear of unit, slides out for easy maintenance

#### Warranty:

- Two year parts and labour; Five years on compressor. For full warranty details visit <https://www.efifoodequip.com/warranty-info.php>



**CSDR1-27VCX Specifications**

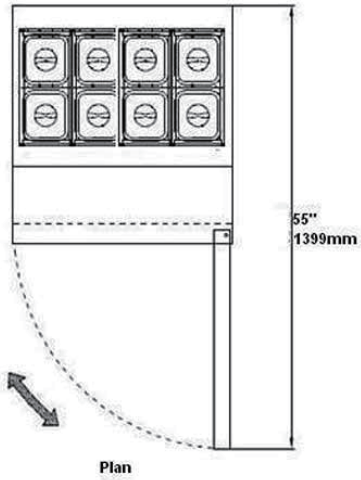
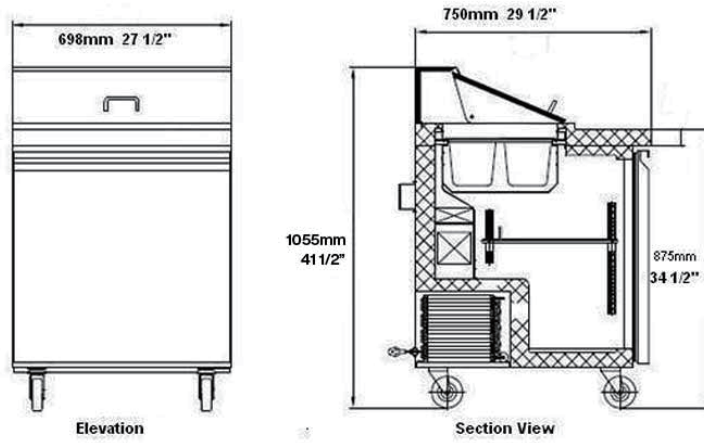

**PAN LAYOUTS**  
8 (pcs) 1/6 pans

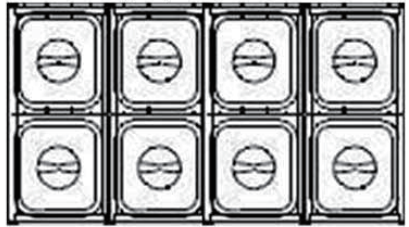

Model	Doors	Shelves	Dimension (mm) (inch)			HP	Voltage	Amps	Capacity (L) (Cu Ft.)	Net Weight (KG) (LBS)	NEMA Config.
			W	D	H						
CSDR1-27VCX	1	1	698	750	1055	2/5	115/60/1	3.6	161.4	80.3	5-15P 
			27.5	29.5	41.5				5.7	177	

Specifications subject to change without notice.



EFI Sales Ltd.  
Toronto Office  
515 Hanlon Creek Blvd  
Guelph, ON N1C 0A1

EFI Sales Ltd.  
Vancouver Office  
26895 Gloucester Way  
Langley, BC V4W 3Y3

Distribution Facilities:  
Toronto, ON  
Langley, BC

(888) 565-9920 Toll Free  
(519) 822-1895 Toronto  
(604) 607-8850 Vancouver  
info@efifoodequip.com  
www.efifoodequip.com