



VERSACHILL

CSDR3-72VC

COOLER 3DR SAND PREP S/S 72in



WARRANTY:
TWO YEAR PARTS AND
LABOUR; FIVE YEARS ON
COMPRESSOR

SPECIFICATIONS SUBJECT TO
CHANGE WITHOUT NOTICE.



CSDR3-72VC 72 INCH 2 DOOR SANDWICH COOLER PREP TABLE

- Heavy-gauge Stainless Steel exterior finish
- Clear coated Aluminum Liner
- Adjustable Heavy-Duty Epoxy-coated shelves
- Casters for easy movement
- Locking doors & drawers w/ magnetic gaskets
- Pan inserts are included with a cutting board, NSF certified
- Positive Seal self-closing doors w/stay open feature

- Sophisticated Digital Controller to ensure a steady temp range from 33 to 40°F (0 to 4°C)
- Automatic defrost system that evaporates defrost water
- Environmentally friendly R290 hydrocarbon refrigerant
- Has temperature preservation & reduces energy consumption design
- Evaporator fan motor conserves energy when door is open
- Inner bottom has round corners for easy cleaning w/ removable door gaskets
- Standard EFI Warranty for Refrigeration and freezer units.

ADDITIONAL IMAGES



MODEL DESIGNATIONS

ADDITIONAL RESOURCES



DIMENSIONS

Dimensions	Width		Depth		Height		Weight	
	Inches	mm	Inches	mm	Inches	mm	Lbs	KG
Exterior	72.7	1,846.0	31.0	787.0	43.7	1,109.0	277.8	126.0
Shipping	74.9	1,903.0	31.9	810.0	48.0	1,220.0	388.0	176.0
Interior	69.1	1,756.0	23.7	601.0	26.2	668.0		

TECHNICAL

Pans	Capacity	Doors	Shelves	Casters	HP	Amps	Voltage	Refrig	Plug	Cord len
18	576/20.3	3	3	4"	1/4	3.2	190.5	R290	NEMA5-15P	≥1.8m

LINE DRAWINGS

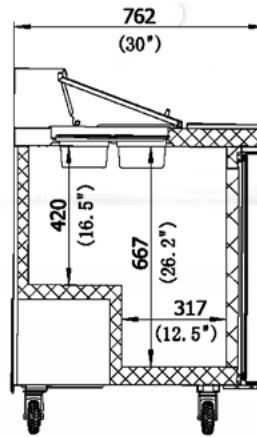
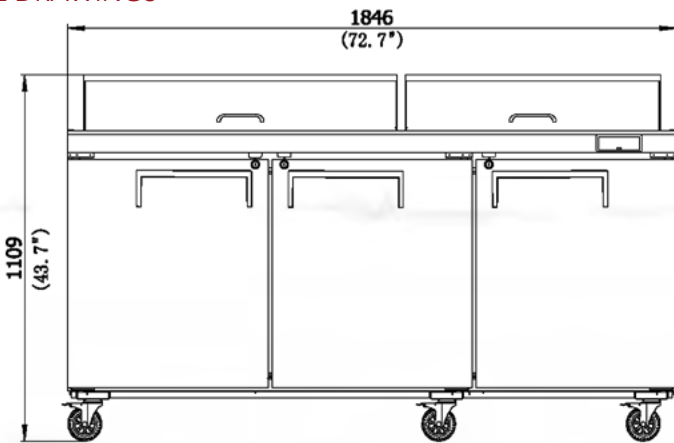

PRODUCT DRAWINGS

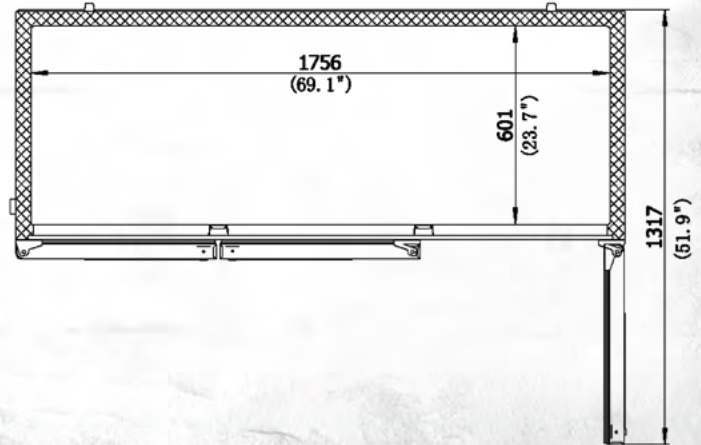
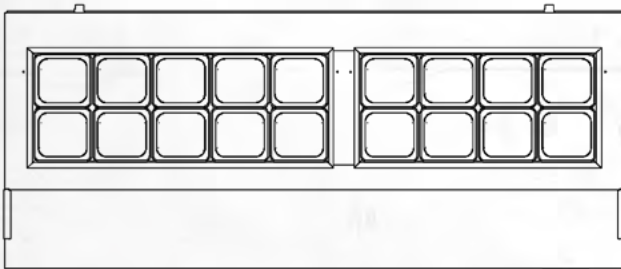

EFI Sales Ltd.
 Toronto Office & DC
 515 Hanlon Creek Blvd.
 Guelph, ON, N1C 0A1

EFI Sales Ltd.
 Vancouver Office & DC
 26895 Gloucester Way
 Langley, BC, V4W 3Y3

(888) 565-9920 Toll Free
 (519) 822-1895 Toronto
 (604) 607-8850 Vancouver