



VERSACHILL

CWDR1-27VC-L COOLER 1DR WORKTOP S/S LH 27in

WARRANTY:
TWO YEAR PARTS AND
LABOUR; FIVE YEARS ON
COMPRESSOR

SPECIFICATIONS SUBJECT TO
CHANGE WITHOUT NOTICE.



CWDR1-27VC-L 27 INCH 1 DOOR REFRIGERATION WORKTOP LEFT HINGE

- Heavy-gauge Stainless Steel exterior finish
- Clear coated Aluminum Liner
- Adjustable Heavy-Duty Epoxy-coated shelves
- Locking doors w/ magnetic gaskets
- Positive Seal self-closing doors w/ stay open feature
- Countertop style work space with backsplash
- Automatic defrost system that evaporates defrost water

- Sophisticated Digital Controller to ensure a steady temp range from 33 to 40°F (0 to 4°C)
- Brilliant Interior LED lighting
- Environmentally friendly R290 hydrocarbon refrigerant
- Has temperature preservation & reduces energy consumption design
- Evaporator fan motor conserves energy when door is open
- Inner bottom has round corners for easy cleaning w/ removable gaskets
- Standard EFI Warranty for Refrigeration and freezer units.

ADDITIONAL IMAGES



DIGITAL
CONTROLLER



BACKSPASH



ADJUSTABLE
SHELF



2" CASTERS



DOOR LOCKS

MODEL DESIGNATIONS

ADDITIONAL RESOURCES



DIMENSIONS

Dimensions	Width		Depth		Height		Weight	
	Inches	mm	Inches	mm	Inches	mm	Lbs	KG
Exterior	27.5	698.0	31.0	787.0	36.9	938.0	136.7	62.0
Shipping	29.3	745.0	31.9	810.0	43.2	1,096.0	168.7	76.5
Interior	23.9	608.0	23.7	601.0	26.7	678.0		

TECHNICAL

Capacity	Doors	Shelves	Casters	HP	Amps	Voltage	Refrig	Plug	Cord len
202/7.1	1	1	2"	1/6	1.6	115	R290	NEMA5-15P	≥1.8m

LINE DRAWINGS

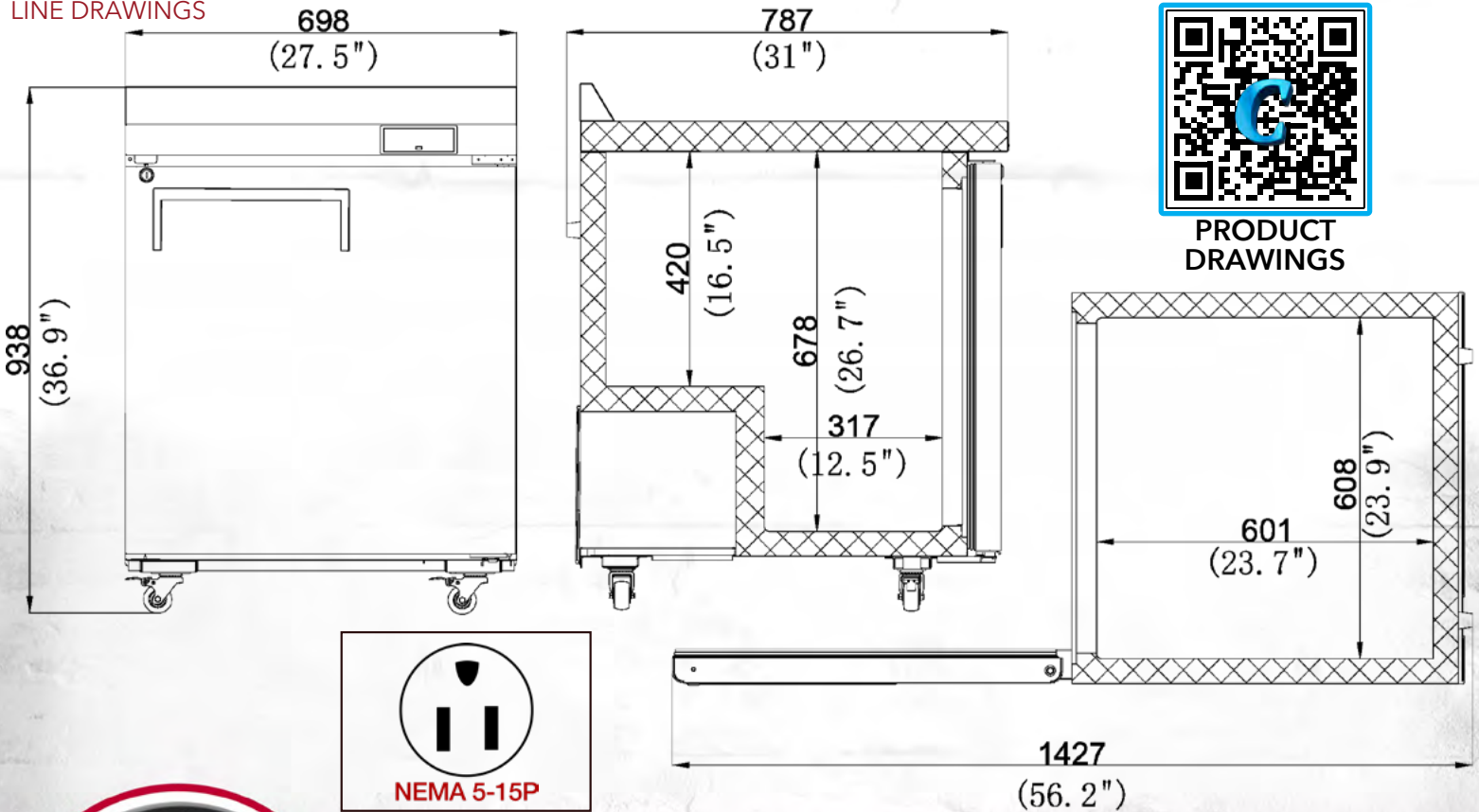

EFI Sales Ltd.
 Toronto Office & DC
 515 Hanlon Creek Blvd.
 Guelph, ON, N1C 0A1

EFI Sales Ltd.
 Vancouver Office & DC
 26895 Gloucester Way
 Langley, BC, V4W 3Y3

(888) 565-9920 Toll Free
 (519) 822-1895 Toronto
 (604) 607-8850 Vancouver

