



# VERSACHILL

## FUDR2-48VC

FREEZER 2DR UNDERCOUNTER S/S 48in

**WARRANTY:**  
TWO YEAR PARTS AND  
LABOUR; FIVE YEARS ON  
COMPRESSOR

SPECIFICATIONS SUBJECT TO  
CHANGE WITHOUT NOTICE.



### FUDR2-48VC 48 INCH 2 DOOR UNDERCOUNTER FREEZER

- Heavy-gauge Stainless Steel exterior finish
- Clear coated Aluminum Liner
- Adjustable Heavy-Duty Epoxy-coated shelves
- Locking doors w/ magnetic gaskets
- Positive Seal self-closing doors w/ stay open feature
- Brilliant Interior LED lighting
- Automatic defrost system that evaporates defrost water

- Sophisticated Digital Controller to ensure steady temp range from -8 to 0°F (-22 to -17°C)
- Environmentally friendly R290 hydrocarbon refrigerant
- Has temperature preservation & reduces energy consumption design
- Evaporator fan motor conserves energy when door is open
- Inner bottom has round corners for easy cleaning w/ removable gaskets
- Standard EFI Warranty for Refrigeration and freezer units.

#### ADDITIONAL IMAGES



DIGITAL CONTROLLER



ADJUSTABLE SHELVES



RECESSED HANDLES



2" CASTERS



DOOR LOCKS

#### MODEL DESIGNATIONS

#### ADDITIONAL RESOURCES



**DIMENSIONS**

Dimensions	Width		Depth		Height		Weight	
	Inches	mm	Inches	mm	Inches	mm	Lbs	KG
Exterior	48.2	1,225.0	31.0	787.0	34.3	872.0	180.8	82.0
Shipping	50.0	1,272.0	31.9	810.0	40.6	1,030.0	238.0	108.0
Interior	44.7	1,135.0	23.7	601.0	26.7	678.0		

**TECHNICAL**

Capacity	Doors	Shelves	Casters	HP	Amps	Voltage	Refrig	Plug	Cord len
368/13	2	2	2"	1/4	2.3	190.5	R290	NEMA5-15P	≥1.8m

**LINE DRAWINGS**

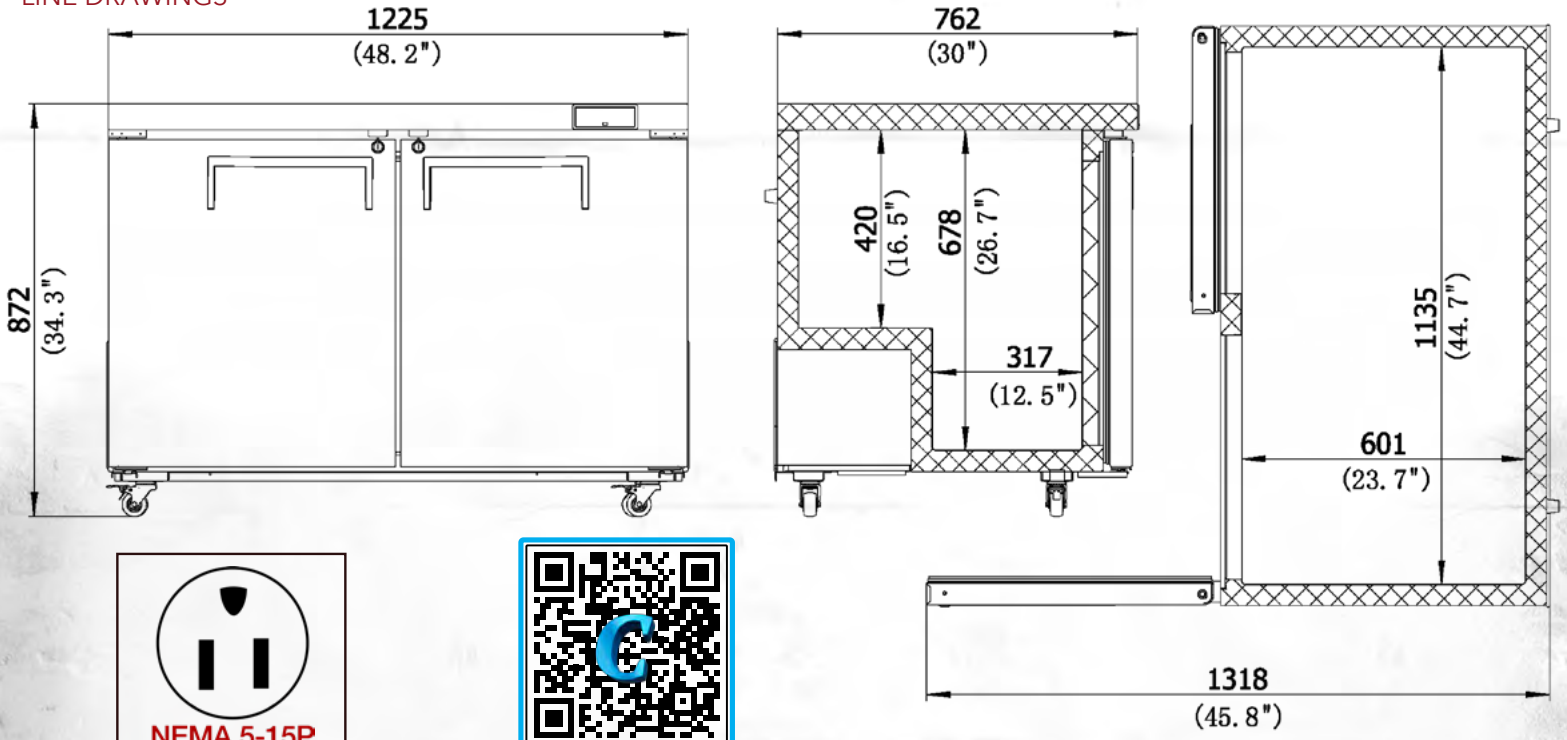

**PRODUCT DRAWINGS**



EFI Sales Ltd.  
 Toronto Office & DC  
 515 Hanlon Creek Blvd.  
 Guelph, ON, N1C 0A1

EFI Sales Ltd.  
 Vancouver Office & DC  
 26895 Gloucester Way  
 Langley, BC, V4W 3Y3

(888) 565-9920 Toll Free  
 (519) 822-1895 Toronto  
 (604) 607-8850 Vancouver