



Equipment for the Foodservice Industry
value + quality + service

X-LINE 60" Worktop Freezer with Backsplash



Model No:
FWDR2-60VCX

FWDR2-60VCX Features

Features:

- Exterior & interior stainless steel construction
- Environmentally friendly R290 refrigerant
- Heavy duty Embraco compressor
- Self-closing and stay open door
- Efficient refrigeration system holds -8°F to 1°F (-22°C to -18°C)
- Recessed door handle
- Removable gasket that is easy to clean and replace
- Casters for easy movement
- Pre-installed shelves

Warranty:

- Two year parts and labour; Five years on compressor. *For full warranty details visit <https://www.efifoodequip.com/warranty-info.php>*



FWDR2-60VCX Specifications

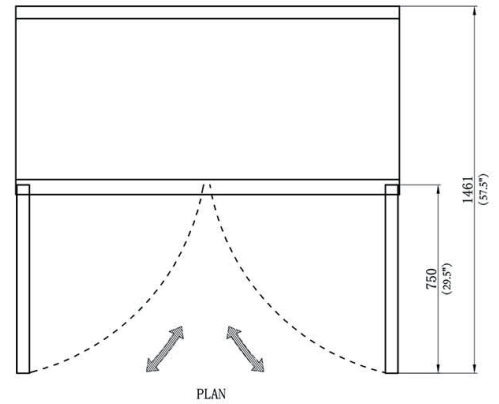
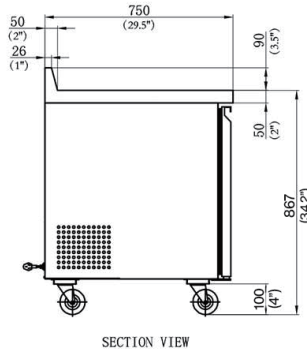
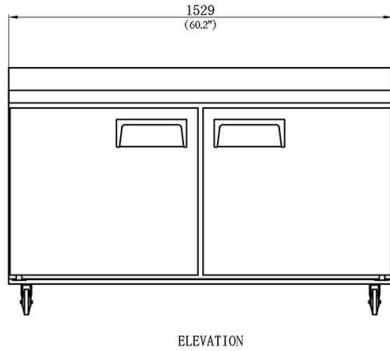

Model	Refrigerant	Doors	Shelves	Dimension (mm / inch)			HP	Voltage	Amps	Capacity (L / Cu Ft.)	Net Weight (KG / LBS)	Temperature Range
				W	D	H						
FWDR2-60VCX	R290	2	2	1529	750	1059	1/3	115/60	2.6	487	106	-8 ~ -1°F
				60.2	29.5	41.7				17.2	233	-22 ~ -18°C

Equipped with one NEMA 5-15P plug 

Shipping Information

Crate Dimensions (mm / inch)			Net Weight (KG / LBS)	Gross Weight (KG / LBS)
W	D	H		
1600	820	1120	115	147
63	32.3	44.1	253.5	324

Specifications subject to change without notice.