



# VERSACHILL

## FWDW2-48VC

### FREEZER 2DW 1DR WORKTOP S/S 48in



**WARRANTY:**  
TWO YEAR PARTS AND  
LABOUR; FIVE YEARS ON  
COMPRESSOR  
**SPECIFICATIONS SUBJECT TO  
CHANGE WITHOUT NOTICE.**



## FWDW2-48VC 48 INCH 2 DRAWER 1 DOOR WORKTOP FREEZER

- Heavy-gauge Stainless Steel exterior finish
- Clear coated Aluminum Liner
- Adjustable Heavy-Duty Epoxy-coated shelves
- Locking doors and drawers w/ magnetic door gaskets
- Countertop style work space with backsplash
- Positive Seal self-closing doors w/ stay open feature
- Automatic defrost system that evaporates defrost water
- Sophisticated Digital Controller to ensure steady temp range from -8 to 0°F (-22 to -17°C)
- Brilliant Interior LED lighting
- Environmentally friendly R290 hydrocarbon refrigerant
- Has temperature preservation & reduces energy consumption design
- Evaporator fan motor conserves energy when door is open
- Inner bottom has round corners for easy cleaning w/ removable gaskets
- Standard EFI Warranty for Refrigeration and freezer units.

#### ADDITIONAL IMAGES



**DIGITAL CONTROLLER**



**ADJUSTABLE SHELF**



**INSERT PANS INCLUDED**



**2" CASTERS**



**DOOR LOCKS**

#### MODEL DESIGNATIONS

#### ADDITIONAL RESOURCES



### DIMENSIONS

Dimensions	Width		Depth		Height		Weight	
	Inches	mm	Inches	mm	Inches	mm	Lbs	KG
Exterior	48.2	1,225.0	31.0	787.0	36.9	938.0	197.7	89.7
Shipping	50.0	1,272.0	31.9	810.0	43.2	1,096.0	257.3	116.7
Interior	44.7	1,135.0	23.7	601.0	26.7	678.0		

### TECHNICAL

Pans	Capacity	Doors	Drawers	Shelves	Casters	HP	Amps	Voltage	Refrig	Plug	Cord len
4	313/11	1	2	1	2"	1/4	2.3	190.5	R290	NEMA5-15P	≥1.8m

### LINE DRAWINGS

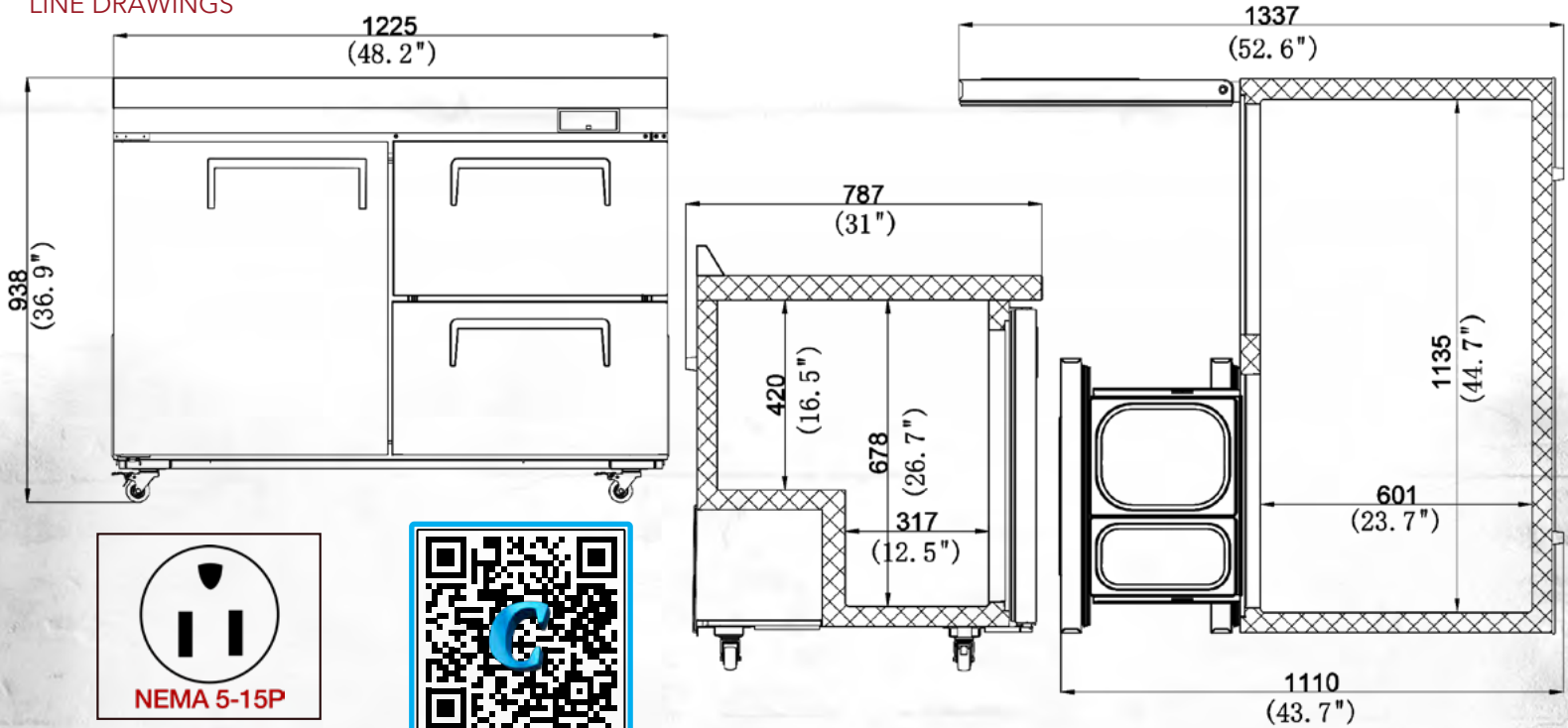

PRODUCT DRAWINGS



EFI Sales Ltd.  
 Toronto Office & DC  
 515 Hanlon Creek Blvd.  
 Guelph, ON, N1C 0A1

EFI Sales Ltd.  
 Vancouver Office & DC  
 26895 Gloucester Way  
 Langley, BC, V4W 3Y3

(888) 565-9920 Toll Free  
 (519) 822-1895 Toronto  
 (604) 607-8850 Vancouver