



Universal Ventless Hood

MODEL WVU-26



Model WVU-26



Model WVU-26
Fryer Sold Separately

DESCRIPTION

Wells Universal hoods are Certified Type-1 compliant, UL710B approved recirculation hood systems and feature completely self-contained air filtration and fire-suppression systems. They do not require venting outside making it possible to cook in non-traditional locations or when traditional Type-1 hoods and duct-work are impractical, restricted or too expensive. Operators may use electric cooking equipment under the hood, including a fryer, griddle, hot plate and more - providing greater flexibility and through-put.

SPECIFICATIONS

Fire Protection – Completely self contained ANSUL® R-102 system includes ANSUL® tank, nitrogen cartridge, ANSUL® saponifier, piping, heat sensors, ANSUL® drops, nozzles, and movable manual pull station. Manual pull can be relocated to the egress position or an additional station can be added by an authorized ANSUL® representative. Fire protection system meets NFPA 96 Chapter 13. Fire protection system must be charged and certified by ANSUL® Authorized distributor after installation and before first use (operator's responsibility).

Filtration – Completely self-contained filtration process reduces emissions below that allowed in NFPA 96 and ANSI UL710B using the EPA 202 test method and includes stainless steel grease baffle filter with grease cup, HEPA (High-Efficiency Particulate Air) filter/ carbon-charcoal filter pack. All filters are easily removable with out tools. Air flow sensors continually monitor air flow optimizing performance and grease removal while an interlock system will not allow cooking appliances to function if filters are missing, clogged or in the event of a fire.

Cooking Appliances – Only electrically heated appliances are acceptable for installation. Cooking equipment is optional from Wells or other manufacturers. Appliances must be installed as per manufacturers instructions and controlled thru the hood equipment shut-off interface through a customer supplied contractor which will disable cooking equipment in the event of fire or hood malfunction. For size, temperature and KW limits see back page or manual.

Exhaust and Air Flow – Exhaust air is vertical discharge. Typical airflow is 800 CFM. A minimum of 400 cubic feet of fresh air per minute is recommended both in and out of the cooking area to ensure the dilution of cooking aromas.

STANDARD FEATURES

- Completely self-contained, 3-stage filtration system
- Completely self-contained fire protections system – now accessible from the front
- Interlock system will disable cooking appliances if filters are missing, clogged or in the event of a fire
- Airflow sensors continually monitor airflow for optimizing performance and grease removal
- Illuminated early-warning system to monitor filter replacement
- Completely self-contained filtration process reduces emissions below that allowed in NFPA 96 and ANSI UL710B using the EPA 202 test method
- Two LED lights producing 990 lumens for improved visibility-light color temperature (cool white)
- Stainless steel construction for strength, durability and ease of cleaning
- Fits through a 36" wide door opening
- 6" to 8" adjustable legs (adjustable by 2" for leveling)
- Universal systems are movable making them ideal for leased properties
- Available in 208/240V, 1 \emptyset
- Limited one-year parts and one year labor warranty**

OPTIONS & ACCESSORIES

- HEPA / carbon-charcoal filter pack: # WL0107

CERTIFICATIONS



WVU-26_2M-Z25035_REV_B_(05-22)





Universal Ventless Hood

MODEL □ WVU-26

SPECIAL ENVIRONMENTAL NOTICE: THE HOOD SYSTEM IS DESIGNED TO REDUCE EMISSIONS BUT WILL NOT COMPLETELY ELIMINATE COOKING AROMAS. AIR EXCHANGE AT THE INSTALLATION SITE MUST COMPLY WITH REQUIREMENTS OF THE LOCAL JURISDICTIONAL AUTHORITY. A MINIMUM OF 400 CUBIC FEET OF FRESH AIR PER MINUTE IN AND OUT OF THE AREA IS RECOMMENDED TO ENSURE ADEQUATE DILUTION.

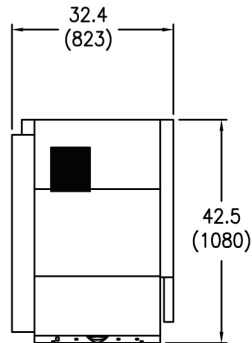

MINIMUM REQUIRED CLEARANCE			
BACK	SIDE	BASE	CEILING
NA NA	NA NA	6 (152)	19 (483)

INCHES
(MM)

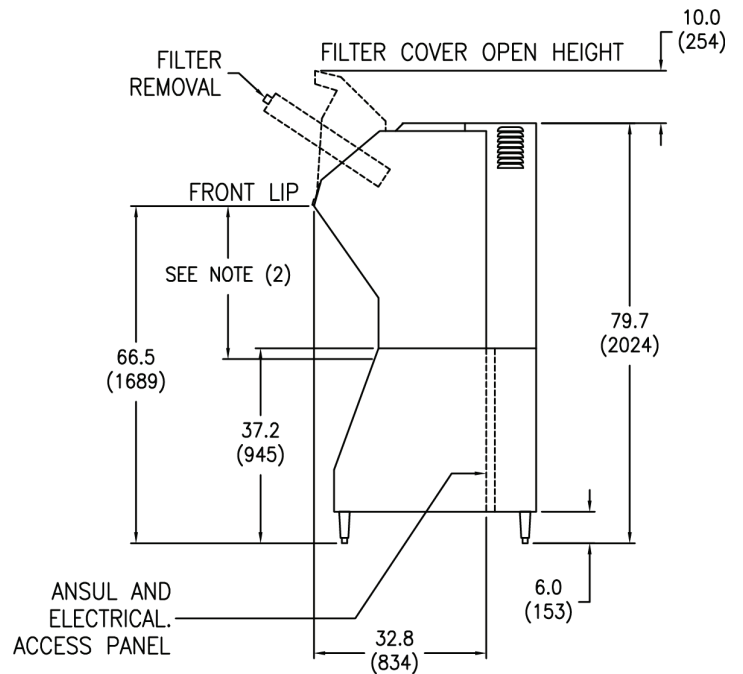
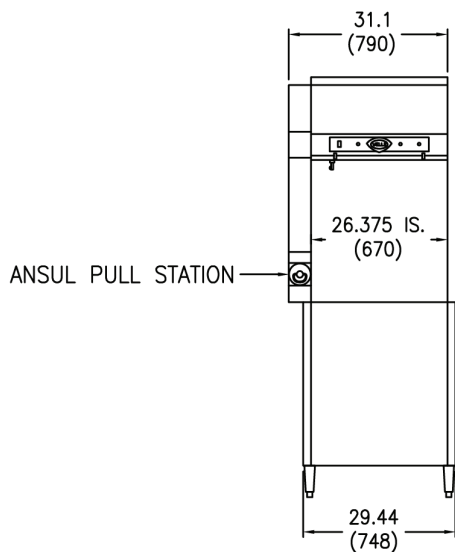

UNDER-HOOD APPLIANCE LIMITS:

- 1) ELECTRICAL APPLIANCES ONLY WITH A MAXIMUM OF 22KW OUTPUT PER 24" (610MM) WIDE HOOD SECTION.
- 2) THE TOP OF THE COOKING SURFACE MUST BE INSTALLED 29.5-33.5" (749-851MM) FROM THE LOWER FRONT LIP OF THE HOOD. NO MORE THAN 24.5" (648MM) FROM BACK WALL, & NO WIDER THAN 24" (610MM)
- 3) ALL APPLIANCES MUST BE INSTALLED PER MANUFACTURER'S INSTRUCTIONS.

UNDER HOOD APPLIANCE INSTALLATION WARNING:

COMPLETELY READ STEP BY STEP INSTALLATION INSTRUCTIONS IN THE MANUAL BEFORE INSTALLING. WIRING MUST BE DONE BY A LICENSED ELECTRICIAN. FAILURE TO FOLLOW INSTRUCTIONS AND WIRING DIAGRAM VOIDS THE WARRANTY.

MODEL	VOLTS	WATTS	AMPS SINGLE PHASE	POWER CONNECTION (NOT INCLUDED)
WVU-26	208/240	1248/1440	6	NEMA 6-15R

Due to periodic changes in designs, methods, procedures, policies and regulations, the specifications contained in this sheet are subject to change without notice. While Wells exercises good faith efforts to provide information that is accurate, we are not responsible for errors or omissions in information provided or conclusions reached as a result of using the specifications. By using the information provided, the user assumes all risks in connection with such use.



Wells Manufacturing 265 Hobson Street, Smithville, Tennessee 37166 U.S.A.
Phone : (800) 264-7827
www.wells-mfg.com • Printed in the U.S.A.

Specifications are subject to change without notice and are not intended for installation purposes. See installation instructions prior to installing the unit.