

# EmberGlo®

## Kabob Gas Char Broiler Models 25 Kabob & 25W Kabob 31 Kabob

**Kabob Char Broilers** - Shish Kabobs have always been a popular dish, celebrated by various cultures for centuries. The EmberGlo Kabob Gas Char-Broiler is incredibly versatile in cooking almost anything that can be placed on a skewer. In a short period of time, a large variety of foods can be broiled effortlessly with that distinctive 'Outdoor Taste' !!



*Kabob Gas Char Broiler  
Model 25WC Kabob*



*Kabob Gas Char Broiler  
Model 25WF Kabob*

The grill top on this commercial grade Broiler is designed especially for broiling Shish Kabobs. The quality stainless steel skewers included with the broiler can accommodate large pieces of meat such as beef, chicken, lamb, pork, seafood or veggies. Foods char-broiled on an EmberGlo keep their delicious natural flavors and juices while retaining that great outdoor char-broiled taste.

The EmberGlo Kabob Gas Char-Broilers have all the great benefits and features of the regular EmberGlo Gas Broilers. They can be ordered as a floor or counter top models, they have NO MESSY GREASE TRAYS to clean, they have the industry's only all ceramic hearth, and they can control your flame flare ups with a patented flick of a switch called "Flaretrol". All 25W Kabob broilers have all stainless steel cabinetry.

*Once you use an EmberGlo Gas Char-Broiler you will never want anything else but an EmberGlo!*



**EmberGlo®**

EmberGlo  
A Div of Midco® International Inc.  
4140 West Victoria Street  
Chicago, Illinois 60646  
toll free 866.705.0514  
tel 773.604.8700  
fax 773.604.4070  
web www.emberglo.com  
e-mail sales@emberglo.com

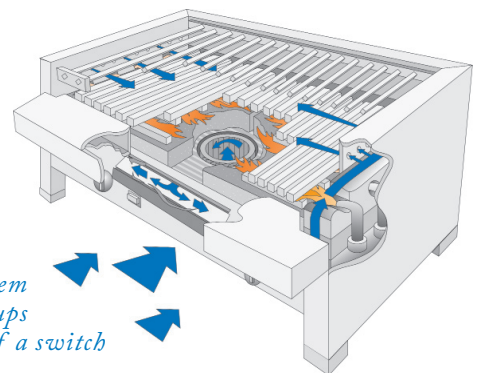

*The Flaretrol® system controls flame flare-ups with a simple flip of a switch*

# Kabob Gas Char Broilers

*Char Broiling at its Best -*

*Kabob Models # 25 Kabob, 25W Kabob and 31 Kabob*

## Kabob Char Broilers Specialized Features

- All Ceramic Broiling Hearth
- Flame Control with our Unique Patented FLARETROL® System
- NO MESSY GREASE trays
- Self Cleaning Hearth
- Single Gas Heat Control Valve
- Optional Cooking Grate
- Zero Recovery Time
- Clog Free, Side Mounted, Inshot 'Cobra' Gas Burner Heads
- 'Outdoor Flavor' - Indoors
- Kabob Broilers Include 10 Stainless Steel Skewers
- Natural or Propane Gas
- All Stainless Steel Construction for the 25W Kabob Broilers

## Flame Controlling Flaretrol® System

The Kabob Broiler features the exclusive Flaretrol® system—the most effective means of flame flare-up control for open hearth broiling. When grease starts to flare-up, simply flip the Flaretrol® switch on and a steady stream of air brings the flames under control.

## Kabob Char Broilers Accessories & Options

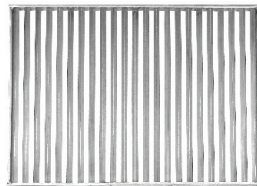

*Stainless Steel  
Cooking Grill Grates*  
25W 4638-30  
25 (Half) 4638-31

*Splash Guards  
Stainless Steel  
Dishwasher Safe  
Set of 2 Sides & 1 Back*

Model Part #  
25W 2060130  
25 2060140  
31N 2060150  
31 2060160  
41 2060170



*Casters  
for floor models  
Set of 4  
2070100*



*Broiler Cleaning  
Brush  
1420-39*



*Stainless Steel Skewers*  
To increase prep time efficiency  
order extra Sets of 10 Skewers  
Models 25 and 25W - 20.5"  
4508-68 Set of 10  
Model 31 - 24"  
4508-69 Set of 10

## Kabob Char Broilers Models 25, 25W & 31

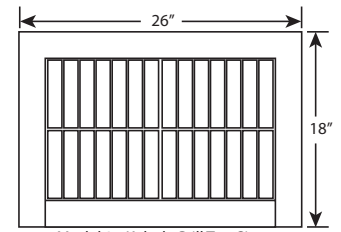

Model 25 Kabob Grill Top Size

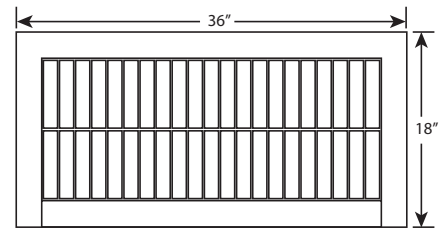

Model 25W Kabob Grill Top Size

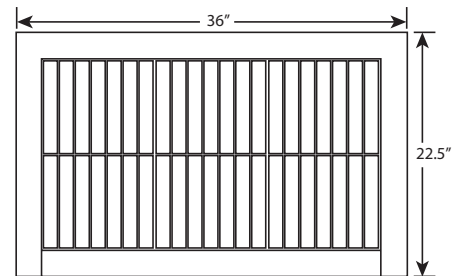

Model 31 Kabob Grill Top Size

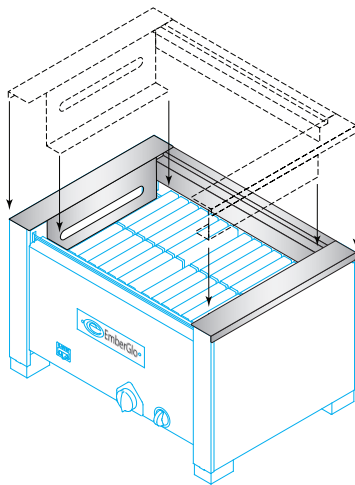

## Specifications - Kabob Broilers

Kabob Model Number	Cabinet Size	Grill Sq. Inch	Grill Size	Flaretrol Amperage	Max Btu/Hr Input	Number of Burners / Btu for Each Burner	Shipping Weight
25C Kabob*	26"w X 18¼"d X 17 <sup>9</sup> / <sub>16</sub> "h	333	21 ¾"w X 15 ⅝"d	120V, 60Hz, 1.5 amp	39,600	6 6,600 Btu/burner	25C - 190 lbs
25F Kabob*	26"w X 18¼"d X 37 to 39"h						25F - 250 lbs
25WC	35 <sup>7</sup> / <sub>8</sub> "w X 18¼"d X 19½"h	480	30 ¾"w X 15 ⅝"d	120V, 60Hz, 1.5 amp	47,200	2 @ 6,600 Btu/burner 4 @ 8,500 Btu/burner	25WC - 240 lbs
25WF	35 <sup>7</sup> / <sub>8</sub> "w X 18¼"d X 40"h						25WF - 305 lbs
31C Kabob*	35 <sup>7</sup> / <sub>8</sub> "w X 22 <sup>5</sup> / <sub>8</sub> "d X 19½"h	657	30 ¾"w X 21 ⅝"d	120V, 60Hz, 1.5 amp	68,000	8 8,500 Btu/burner	31C - 310 lbs
31F Kabob*	35 <sup>7</sup> / <sub>8</sub> "w X 22 <sup>5</sup> / <sub>8</sub> "d X 41"h						31F - 400 lbs

\* Kabob broilers come with a set of skewers, the grill grate is optional and can be purchased separately

- All floor and counter models are identical except for the addition of a floor stand on "F" models  
- Specify natural or propane gas when ordering



EmberGlo - A Division of Midco International - 4140 West Victoria Street - Chicago, Illinois 60646

toll free: 866 705 0515 - tel: 773.604.8700 - fax: 866.580.8700 - web: www.emberglo.com - e-mail: sales@emberglo.com

822  
8475 04  
Printed in USA